



Fun with Physics

Teacher Manual

Dear Teacher:

Welcome to Holiday World & Splashin' Safari. Our existence and continued success depends on our being able to devise rides where you can safely experience as many different accelerations as possible. Very few people would be interested in a ride that moves in a straight line at constant speed!

Included in the Student Manual are questions and problems concerning the physics involved in our rides. We hope you will take the opportunity to apply the physics you have learned in the classroom to a real world situation and have fun at the same time. While you are making the observations and taking measurements we would appreciate it if you would observe the following rules to insure your safety and the safety of others.

- If you plan to participate in the activities included in this manual you must contact our group sales office at 1-800-467-2682. This will give us the opportunity to prepare our ride operators for your visit.
- Your activities must not interfere with the operation of any ride or interfere with a park employee's job.
- Students must obey all park safety rules and regulations. Failure to follow rules may result in ejection from the park.
- Students should determine the data they will need before riding. The accelerometer should not be used unless the question specifically states.
- No restricted areas or safety zones are to be entered to obtain data readings. All data can be obtained from general public areas. Students should not attempt to take measurements of the ride units.
- Students must follow all rider policies; including riding with all safety restraining devices in place, and riding flush against the seat. Riders must not ride sideways, twisted, or leaning forward.
- Students must secure all loose articles before riding. Non-riding students may hold the materials and wait at the bottom of the exit while the rest of the group rides.
- Show proper respect to other park guests.
- Students must notify the coaster operator that they are participating in Fun with Physics program. They will be required to sit in the last row of the coaster. If there are other students in line that are participating, they will have to wait for the next ride.

Procedures to Discuss With Students before Trip

- I. Equipment that you will need and must bring with you.
1. Protractor (cardboard) with attached button on string.
 2. Two meter (or there about) tape measure or calibrated string.
 3. Timing device such as a wrist watch. One with digital readout is best.
 4. Money for lunch and snacks.
 5. Pencils and note paper.
- II. Helpful Hints.
1. Determine what data you need before going on a ride.
 2. You cannot get too much data. Too little is a problem.
 3. Do not lose your data.

Directions to Assemble Accelerometer

1. Cut out and paste on cardboard.
2. Tape plastic straw to bottom of cardboard protractor.
3. Attach string with button through hole on bottom of protractor.

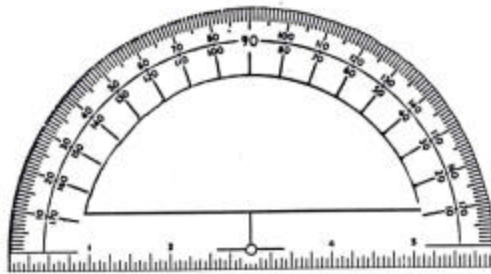

Using the Accelerometer

When you move at a constant velocity, external force acting on the mass m of your accelerometer is the gravitational force mg . It is balanced by the tension T in the rope, since m is in the equilibrium. (See Fig. A) Hence $\theta = 0$. When you are experiencing an acceleration a , the effect of the acceleration is transmitted to the mass through the string. We see (Fig. B) that the magnitudes (sizes) of the gravitational and horizontal accelerations determine the magnitude of the angle θ . The tension in the string provides the upward force mg to hold the mass (since the mass is in vertical equilibrium) as well as the external force ma acting on the mass as a result of the accelerometer's (and your) acceleration. Hence, (See Fig. C).

$$\begin{array}{ll} (1) & T \sin \theta = mg \\ (2) & T \cos \theta = ma \\ \text{Dividing (1) by (2)} & \frac{T \sin \theta = mg}{T \cos \theta = ma} \end{array}$$

$$\tan \theta = \frac{g}{a}$$

Hence, by measuring the angle directly with your accelerometer, you may determine your acceleration on a particular ride.

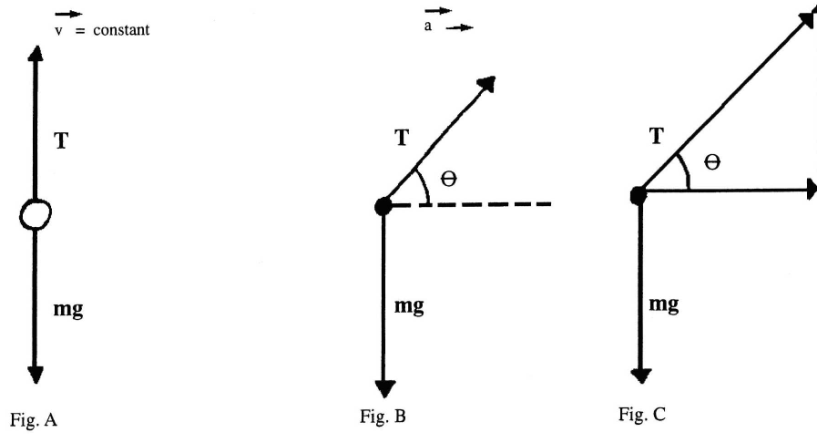

Using the Accelerometer (without Trig)

1. While moving on a particular ride, observe the angle B that your accelerometer string makes with respect to the protractor.
2. Using the angle (we will call it Beta), construct a triangle to scale using the acceleration due to gravity (10M/sec) as the vertical leg. (See figure B below)
3. After completing scale drawing, measure the horizontal leg of the triangle.
4. Using your scale factor, convert this length into the appropriate value in M/sec.
5. The value obtained in (4) is the acceleration you were experiencing at the time you measured B .

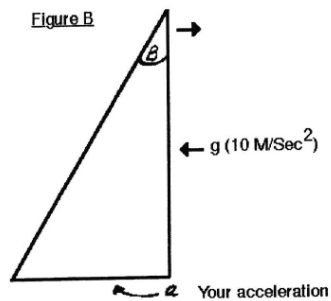
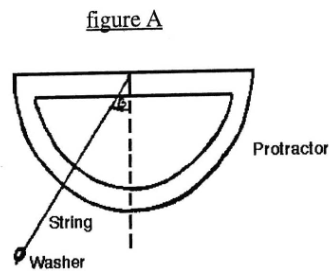

Height h can be determined knowing Θ_1 , Θ_2 , and b .

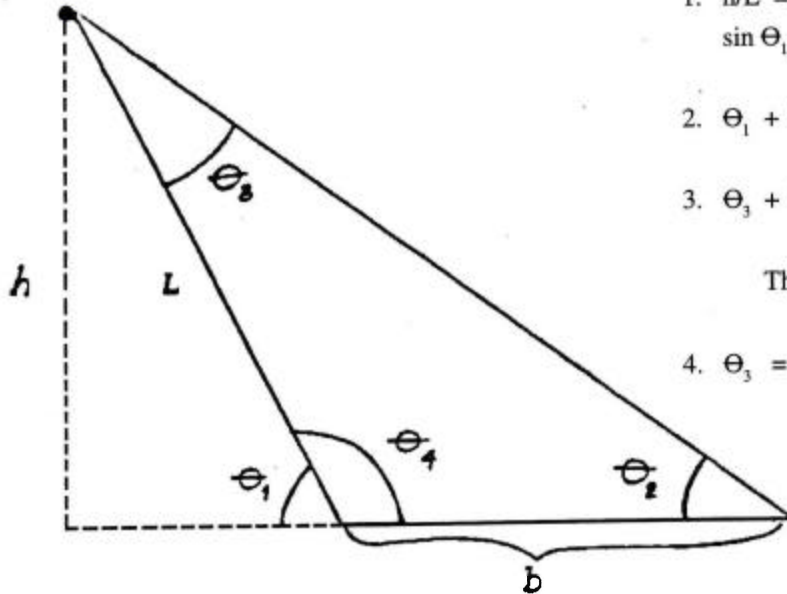

$$1. \frac{h}{L} = \sin \Theta_1; \quad h = L \sin \Theta_1$$

$$2. \Theta_1 + \Theta_4 = 180$$

$$3. \Theta_3 + \Theta_2 + \Theta_4 = 180$$

Therefore,

$$4. \Theta_3 = \Theta_1 - \Theta_2$$

We can find L using the Law of Sines.

$$5. \frac{L}{\sin \Theta_2} = \frac{b}{\sin \Theta_3}$$

Therefore,

$$L = \frac{\sin \Theta_2}{\sin \Theta_3} * b$$

$$\text{From 1 above, } h = L(\sin \Theta_1) = \frac{(\sin \Theta_2)}{(\sin \Theta_3)} * (\sin \Theta_1) * b$$

Vertical Accelerometer

How to Make a Vertical Accelerometer

1. Start with a one foot length of rigid plastic tubing. Tubing should be $\frac{3}{4}$ inch in diameter.
2. You will now need a rubber stopper that will snugly fit in the tube, and has a hole through the middle.
3. Attach a 1 oz. egg fishing weight to the stopper using a rubber band.
4. The length of the rubber band should be adjusted so that the fishing weight hangs down about half way down the tube.
5. To calibrate the accelerometer, a loop of string so that the additional weight can be hung.
6. The new position of the weight is labeled with a marking pen or tape. Ehen there is only one weight, the level should be labeled a one g. (Two 1 oz. weights would be 2 g's and 3, 3 g's, etc.)
7. If the tube is laid on it's side, so that the rubber band is slack, this corresponds to zero g's. Label this on the accelerometer.

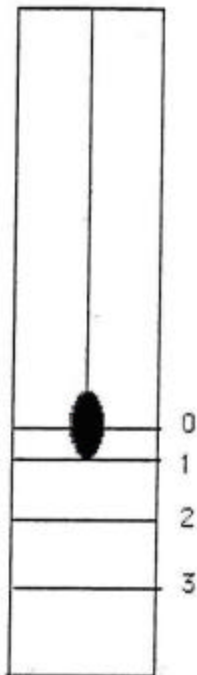

Revolution

The Revolution is a ride consisting of a large rotating wheel having a diameter of 8.8 meters with individual cells in which the riders stand. The wheel spins counter clockwise first in a horizontal position, then tilts up to a maximum angle of 65 degrees above the horizontal. The top speed reaches 19 RPM.

The rate of spin is sufficient to cause the rider to remain in a fixed position pressed against the back of the cell NOTE: If you are susceptible to motion sickness, fix your eyes on a person directly across from you when riding the Revolution. Do not turn your head from side to side.

Questions:

1. While observing the Revolution from the viewing area, determine the maximum rate of spin in revolutions per minute.
2. Calculate the circumference of the wheel.
3. Calculate the tangential velocity.
4. Calculate the centripetal acceleration.
5. Calculate the centripetal force on your body when riding the Revolution.
6. What is your kinetic energy at maximum rotation?
7. How much work is done on your body by the Revolution in one revolution at maximum speed?
8. If the apparatus is 25 percent efficient, how much power is needed to move you one revolution at maximum speed?

Liberty Launch

Liberty Launch is an eight-story “double shot” tower ride that accelerates riders vertically upward and then allows the riders to experience a free-fall sensation as they return to earth.

Questions:

1. Using triangulation, determine the maximum height that the Liberty Launch raises above its equilibrium position.
2. Determine the time required to accelerate to the highest position.
3. Calculate the average upward acceleration in meters per second squared, and convert this value to gs.
4. Calculate the downward acceleration to the ride and convert this value to gs.
5. If a student has a mass of 75.0 kg, what is the perceived weight as the student is moving upward and perceived the weight as the student is moving downward.
6. While riding the Liberty Launch, use a vertical accelerometer and observe the readings while rising the falling and compare this to your calculated values.
7. Calculate the power in kilowatts needed to lift a 75.0 kg student to the top most position.

The Voyage

The Voyage is Holiday World's top air-time rollercoaster. As is the case with most rollercoaster's, electrical energy is used to lift the cars to the top of the initial hill, and then gravitational energy provides the rest of the ride. Before riding the Voyage, try to observe the cars through several cycles.

Questions:

1. Draw a rough sketch of the entire path of the Voyage and label the following points:
 - a. Where the gravitational potential energy is the greatest
 - b. Where the gravitational potential energy is the least
 - c. Where the kinetic energy is the greatest
 - d. Where the kinetic energy is the least
2. While riding the Voyage observe the reading on your accelerometer:
 - a. Climbing the first hill
 - b. At the top of the first hill
 - c. Going down the first hill
 - d. At the bottom of the first hill
 - e. Ascending the second hill
3. Determine the gravitational potential energy in Joules of your body at the top of the first hill.
4. If 100 percent of the loss in potential energy is converted to kinetic during the first drop, calculate your speed in meters per second at the bottom of the first hill.

Reminder: Students must notify the coaster operator that they are participating in the Fun with Physics program. They will be required to sit in the last row of the coaster. If there are other students in line that are participating, they will have to wait for the next ride.

Scarecrow Scrambler

The Scarecrow Scrambler is a dual-axis turning ride. It presents a case of epicycle motion. The ride consists of three large arms, each of which is attached to a cluster of four rider compartments. The length of each large arm, R , is 4.4m, and the length of each small arm, r , is 2.7m.

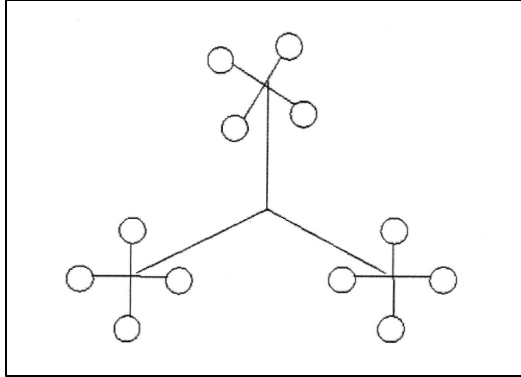

Questions:

1. As viewed from above, is the motion of the three large arms clockwise or counterclockwise?
2. As viewed from above, is the motion of each cluster of rider compartments clockwise or counterclockwise?
3. Measure the period of the large arms.
4. Measure the period of the small arms.
5. Using the frame of reference above the center of the ride, sketch the path of a particular rider for one full turn of the large arms. On your sketch, label the following:
 - a. Points of highest velocity
 - b. Points of lowest velocity
 - c. Points of highest acceleration
 - d. Points of lowest acceleration
 - e. Points of greatest force
 - f. Points of least force
6. After riding the Scarecrow Scrambler calculate the maximum and minimum centripetal forces acting on your body during one complete turn of the large arms.